

**Additional maintenance work
Recommended structural steel-work inspection**

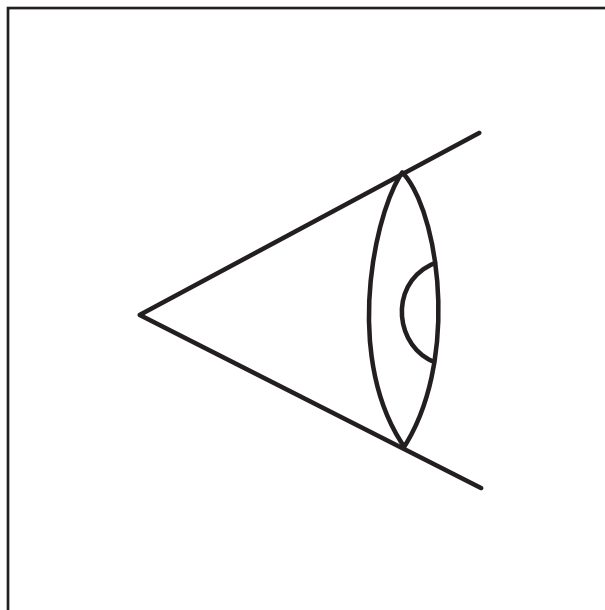

3 302 970 en
07.01.2020

Important note

Any type of duplication or excerpt from this document, even in electronic form, is not subject to the revision service of **Manitowoc Crane Group Germany GmbH**.

© Copyright reserved by

Manitowoc Crane Group Germany GmbH
Industriegelände West

D-26389 Wilhelmshaven, Germany

Phone: [+49] (0)44 21 294-0

Fax: +[49] (0) 44 21 294-301

The distribution or duplication of this document as well as the utilisation and disclosure of its contents are prohibited unless expressly permitted. Infringement will incur liability for compensation. All rights pertaining to registration of patent or utility model are reserved. The original language of this document is German.

1 Additional maintenance work – structural steel-work inspection

| | | |
|------------|---|--------------|
| 1.1 | Additional monthly maintenance work | 1 - 1 |
| 1.1.1 | Additional maintenance plan M 1 | 1 - 1 |
| 1.2 | Recommended structural steel-work inspection | 1 - 3 |
| 1.2.1 | Important notes. | 1 - 3 |
| 1.2.2 | Inspections on the carrier | 1 - 4 |
| 1.2.3 | Inspections on the superstructure. | 1 - 5 |
| 1.2.4 | Inspections on the main boom | 1 - 6 |
| 1.2.5 | Inspections on the lattice extension | 1 - 7 |

1 Additional maintenance work – structural steel-work inspection

1.1 Additional monthly maintenance work

Regular Inspection and Maintenance are a key component in keeping your crane in proper working condition. To further clarify the necessary structural steel-work inspections, **Manitowoc Crane Care** is providing this supplemental structural steel-work inspection instruction to be performed once a month as part of the current daily visual inspection of the crane.

Especially when unnoticed overloading occurs during crane operation, total failure of the steel construction can be prevented through early detection of cracks, deformation, dents and kinks in the structural steel-work.



Risk of accidents if inspection is not carried out!

Always perform all necessary inspections. If you discover any damage, contact **Manitowoc Crane Care**. This will prevent accidents during later work applications.

1.1.1 Additional maintenance plan **M 1**

| | |
|---|--|
| Maintenance work on the CARRIER: monthly / after approx 2,000 km | |
| Steel construction – Visual inspection | ▣▣▣▣▶ p. 1 - 4 |
| Maintenance work on the SUPERSTRUCTURE and LATTICE EXTENSION: monthly / after 100 oper. hrs. | |
| Steel construction, visual inspection – Visual inspection of the superstructure – Visual inspection of the main boom – Visual inspection of the lattice extension | ▣▣▣▣▶ p. 1 - 5 ▣▣▣▣▶ p. 1 - 6 ▣▣▣▣▶ p. 1 - 7 |

Blank page

1.2

Recommended structural steel-work inspection

1.2.1

Important notes



Risk of accidents if inspection is not carried out!

Always perform all necessary inspections. If you discover any damage, contact **Manitowoc Crane Care**. This will prevent accidents during later work applications.

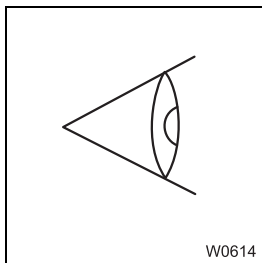

Various inspections and checks are to be performed, depending on the part and area:

- Checks for general damage such as cracks, deformation, dents, kinks.
- Inspection of the welds for damage.
- Checking for completeness and loss of elements.
- Checking for leaks.
- Inspection of the ropes, hoist brake and slewing bearing torque according to the specifications in the maintenance manual.



The figures are for orientation only and do not apply to a specific crane type.

1.2.2

Inspections on the carrier

M 1

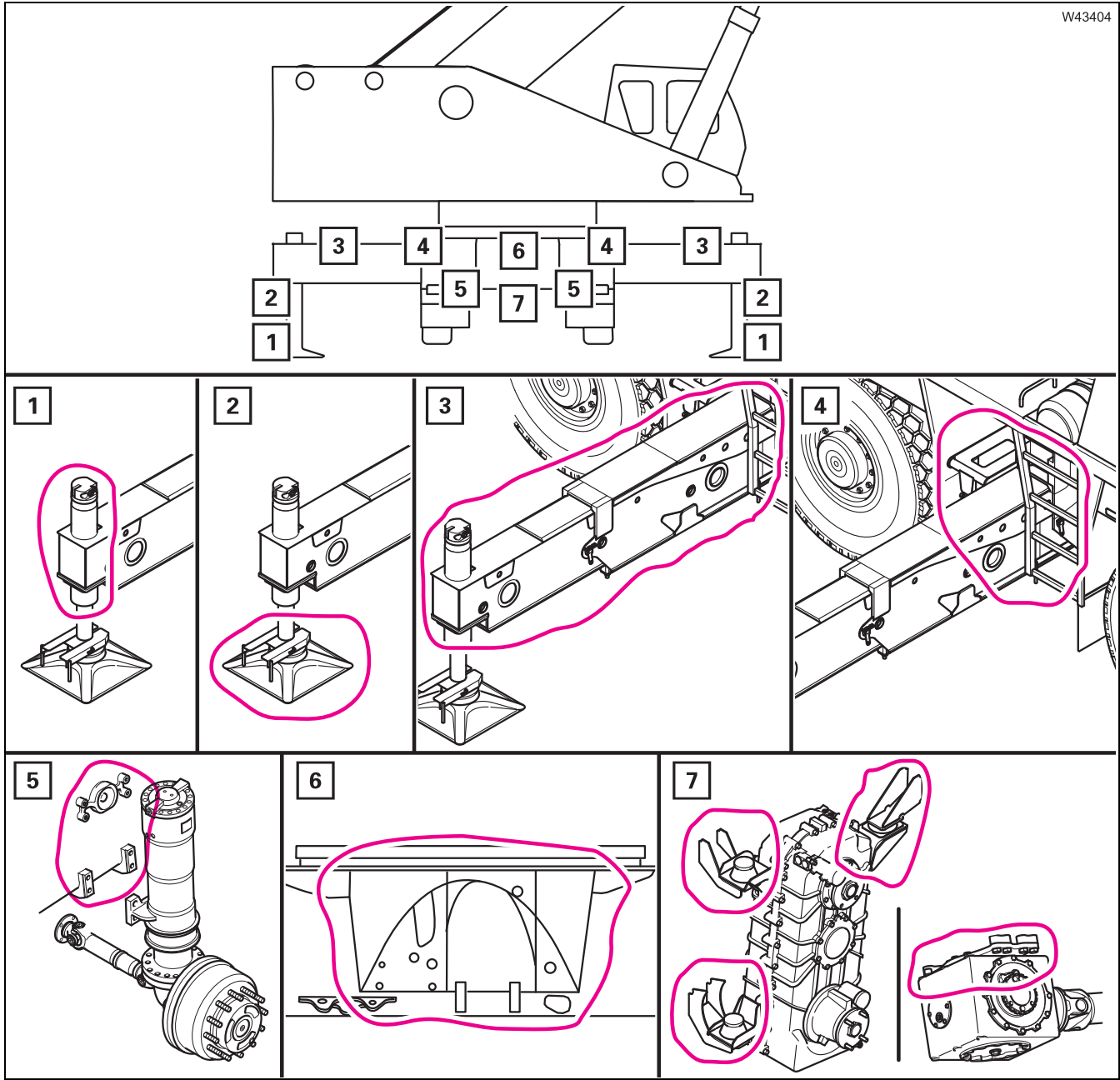

W43404

| | |
|--|--|
| <p>1 All outrigger cylinders – leaks</p> | <p>2 All outrigger pads</p> |
| <p>3 All outrigger beams</p> | <p>4 All outrigger boxes</p> |
| <p>5 Chassis frame – Suspension struts area</p> | <p>6 Chassis frame – slewing bearing area</p> |
| <p>7 Chassis frame – transfer case area Chassis frame – axle centre drives area</p> | |

07.01.2020

1.2.3

Inspections on the superstructure

M 1

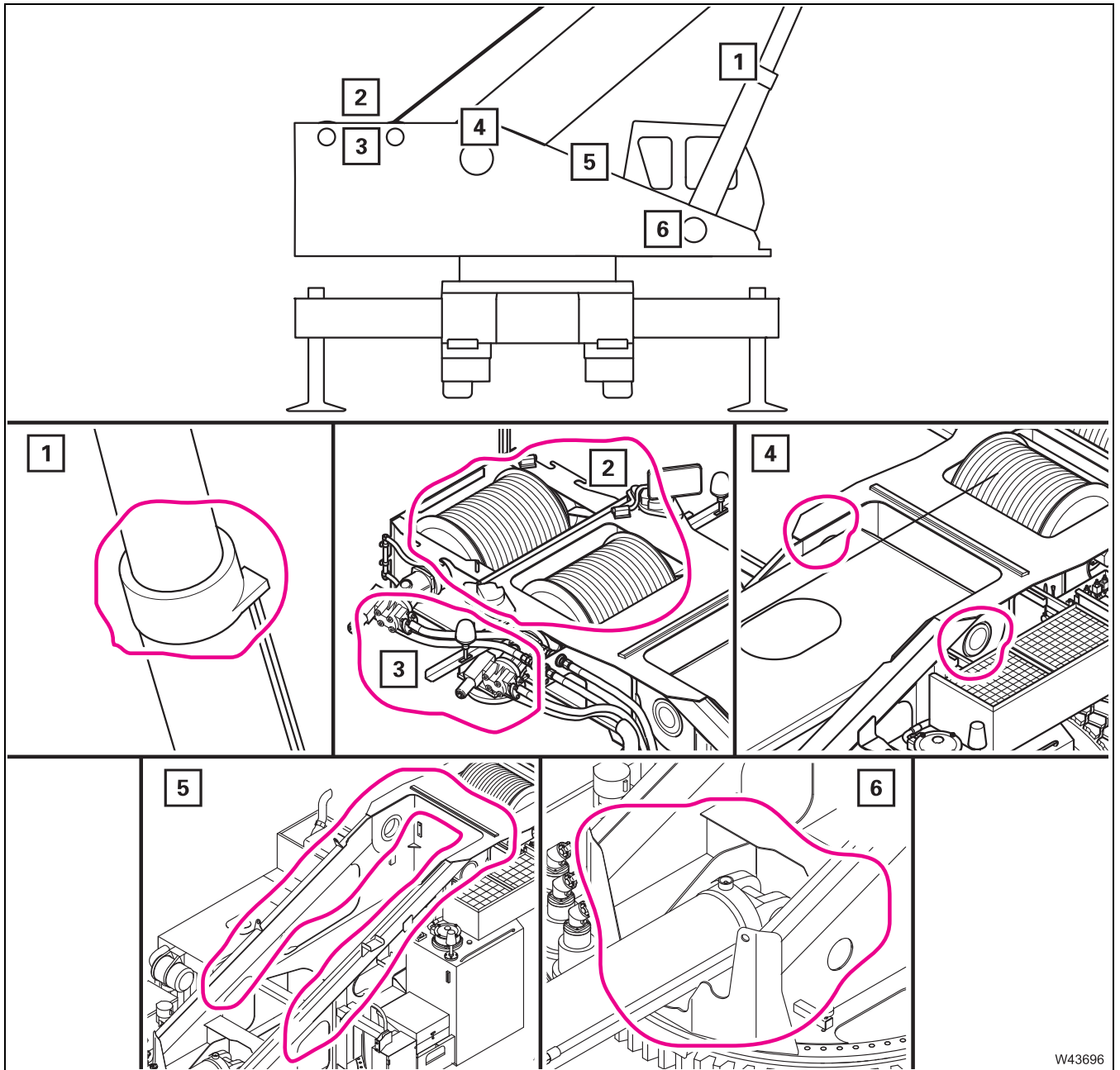

W43696

| | | | |
|----------|-----------------------------|----------|---------------------------------|
| 1 | Derricking cylinder – leaks | 2 | Hoists, hoist drums |
| 3 | Hoist brake – function | 4 | Main boom pivot pin bearing |
| 5 | Turntable area | 6 | Derricking cylinder – foot area |

1.2.4

Inspections on the main boom

M 1

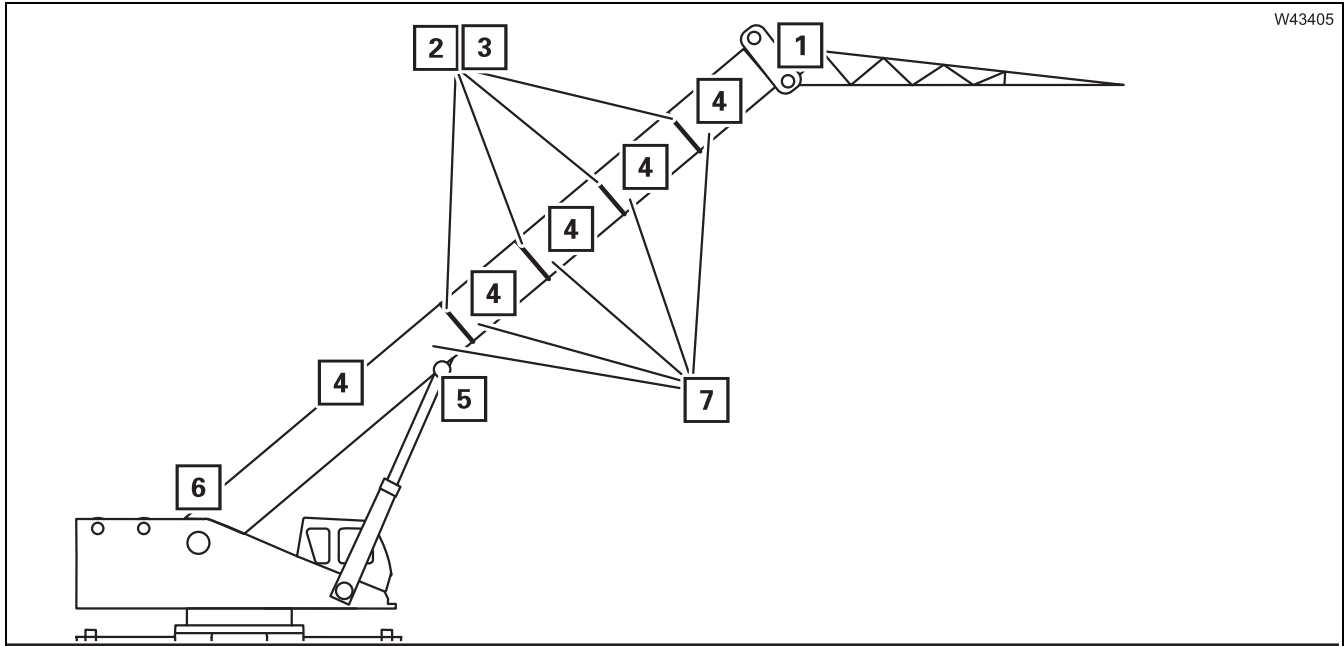

W43405

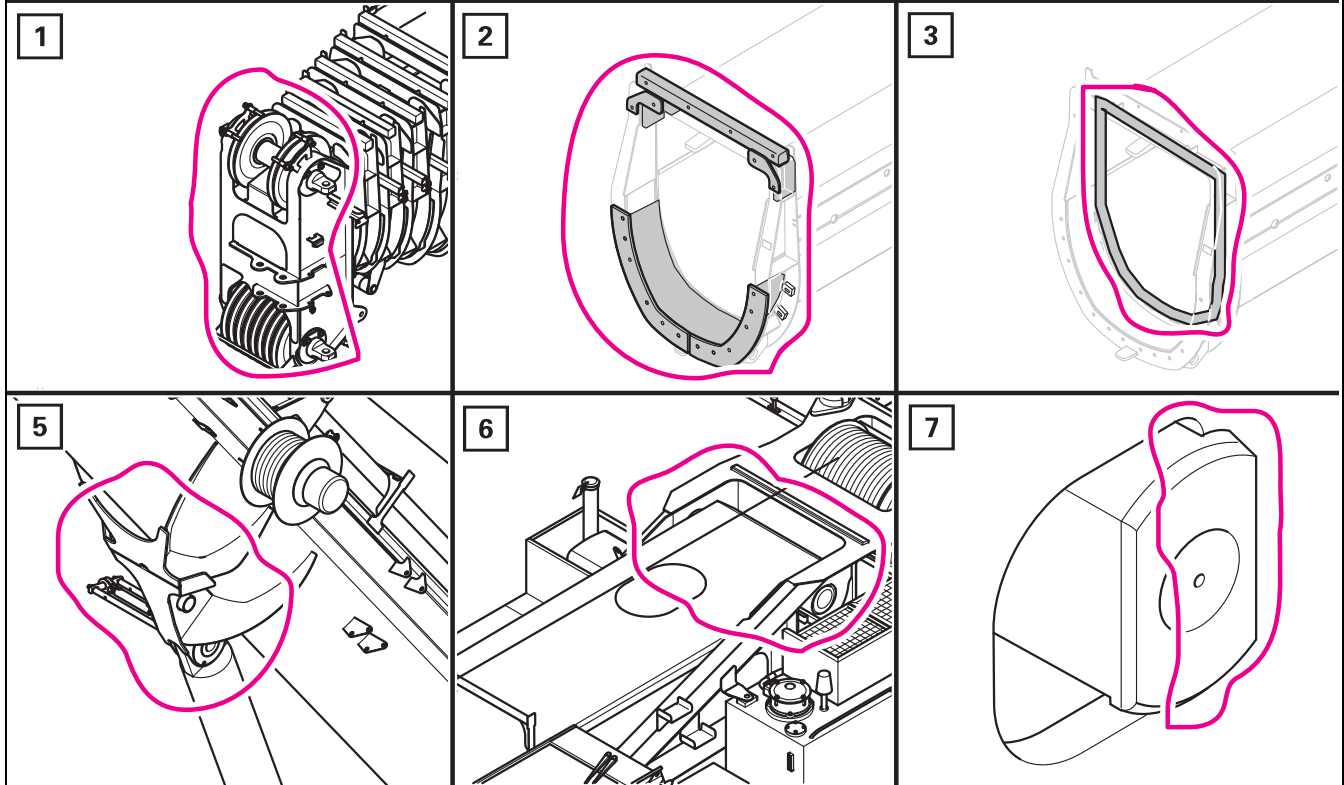

| | | | |
|---|---------------------------------|---|---------------------------|
| 1 | Sheaves, rope guides | 2 | Collars – wear pads |
| 3 | Collars – welds | 4 | Telescopic sections |
| 5 | Derricking cylinder – head area | 6 | Basic section - foot area |
| 7 | Locking areas | | |

07.01.2020

1.2.5

Inspections on the lattice extension

M 1

W43406

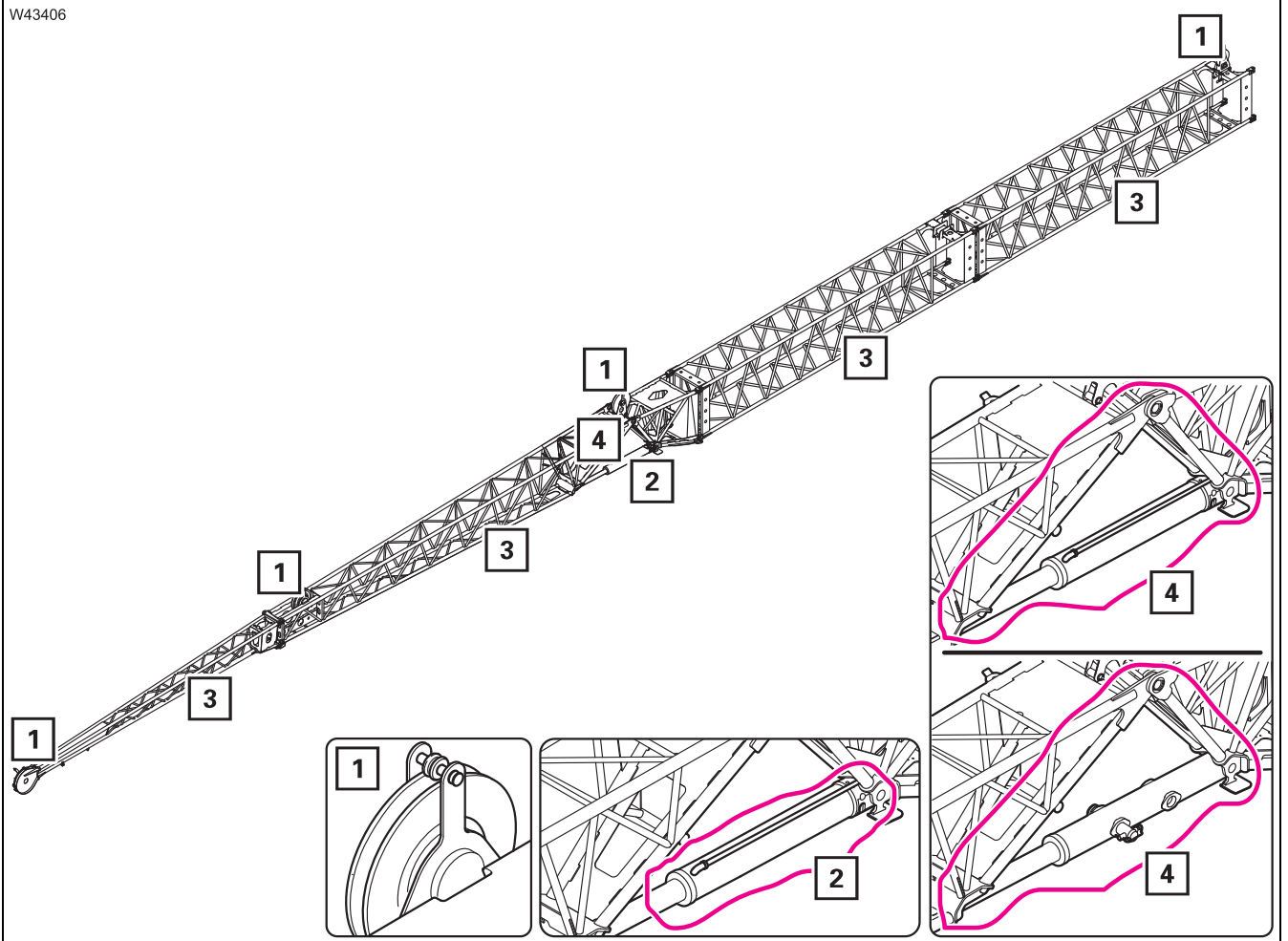

| | | | |
|----------|--------------------------------------|----------|-----------------------------|
| 1 | Sheaves, rope guides | 2 | Derricking cylinder – leaks |
| 3 | Lattice mast sections, fork elements | 4 | Angle piece area |

Blank page

